

Course Code: MEC208

Engineering Materials

-Dr. Vivek Roy

vivek.roy23@gmail.com

Cabin 15, R: 55 – 302.

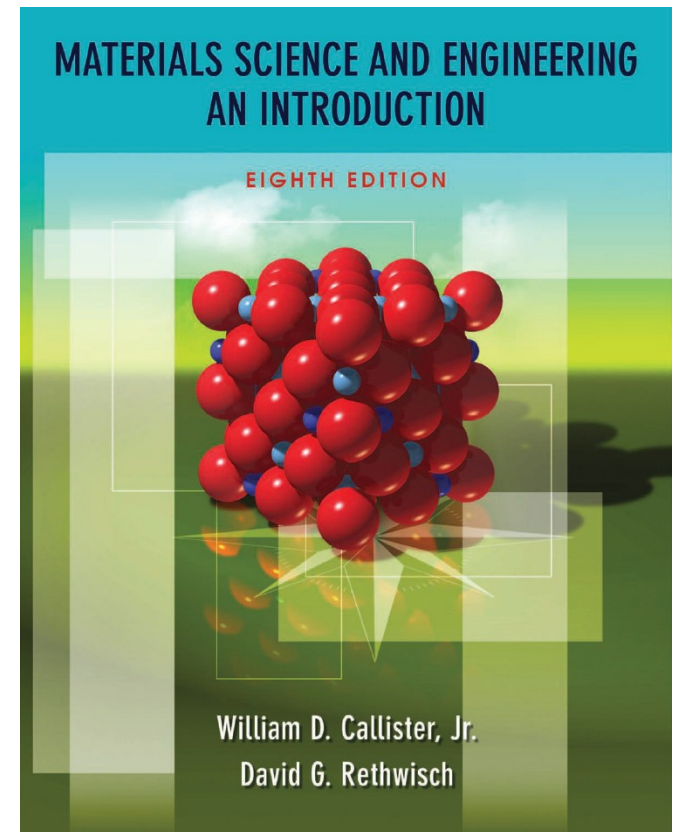

Most of the images are courtesy of the book “Material Science and Engg. an Introduction” by William D. Callister, Jr. & David G. Rethwisch.

Few were adopted from “ The Science and Engineering of Materials” by Donald. R. Askeland. Images collected from Wikipedia and google images were also used.

Unit 5:

Heat Treatment Processes

Annealing: Annealing

➤ Annealing involves heating the material to a predetermined temperature and hold the material at the temperature and cool the material to the room temperature slowly. The process involves:

- 1) Heating of the material at the elevated or predetermined temperature
- 2) Holding the material (Soaking) at the temperature for longer time.
- 3) Very slowly cooling the material to the room temperature.



Annealing:

➤ **Annealing**
The various purpose of these heat treatments is to:

- 1) Relieve Internal stresses developed during solidification, machining, forging, rolling or welding,
- 2) Improve or restore ductility and toughness,
- 3) Enhance Machinability,
- 4) Eliminate chemical non-uniformity,
- 5) Refrain grain size, &
- 6) Reduce the gaseous contents in steel.

The Temperature Transformation (TTT) Diagram:

- TTT diagram is a plot of **temperature** versus the **logarithm of time** for a steel alloy of definite composition.
- It is used to determine when transformations begin and end for an isothermal heat treatment of a previously **austenitized** alloy.
- TTT diagram indicates when a specific transformation starts and ends and it also shows what percentage of transformation of austenite at a particular temperature is achieved.

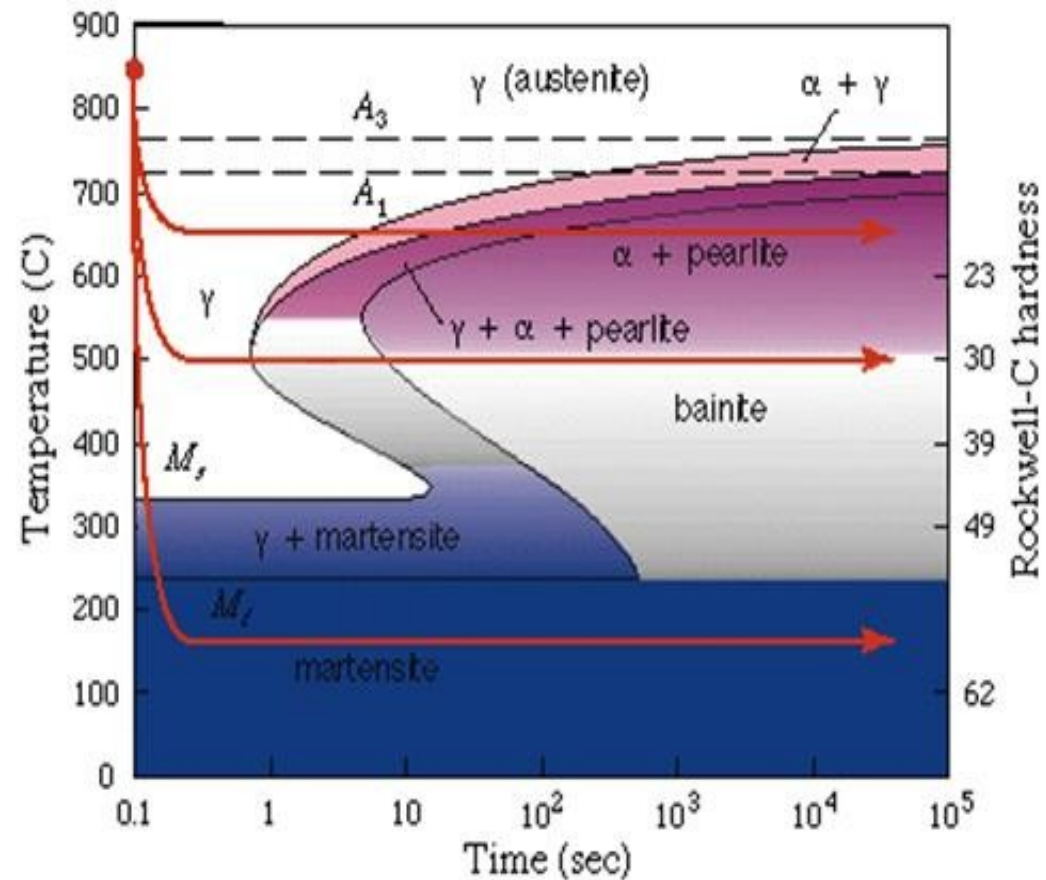

Temperature Transformation (TTT) Diagram:

➤ Depending on the type of heat treatment, time and temperature, final microstructure of the steel, or any Iron carbon will be changed and so does the properties.

Strength ↑	Martensite	↓ Ductility
	T Martensite	
	Bainite	
	Fine Pearlite	
	Coarse Pearlite	
	Spheroidite	
	General Trends	

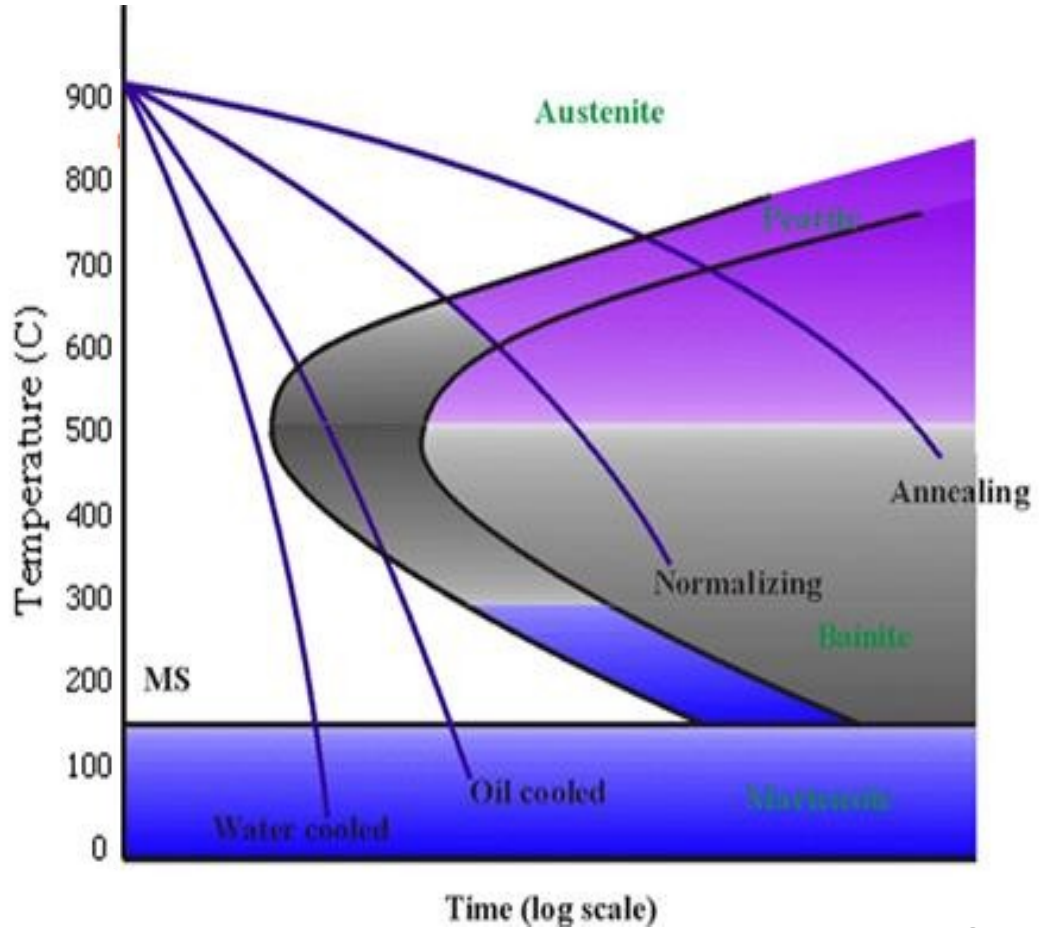

Time Temperature Transformation (TTT) Diagram:

Iron-carbon alloy
with Eutectoid
(0.8 % C)
composition.

- A: Austenite
- P: Pearlite
- B: Bainite
- M: Martensite

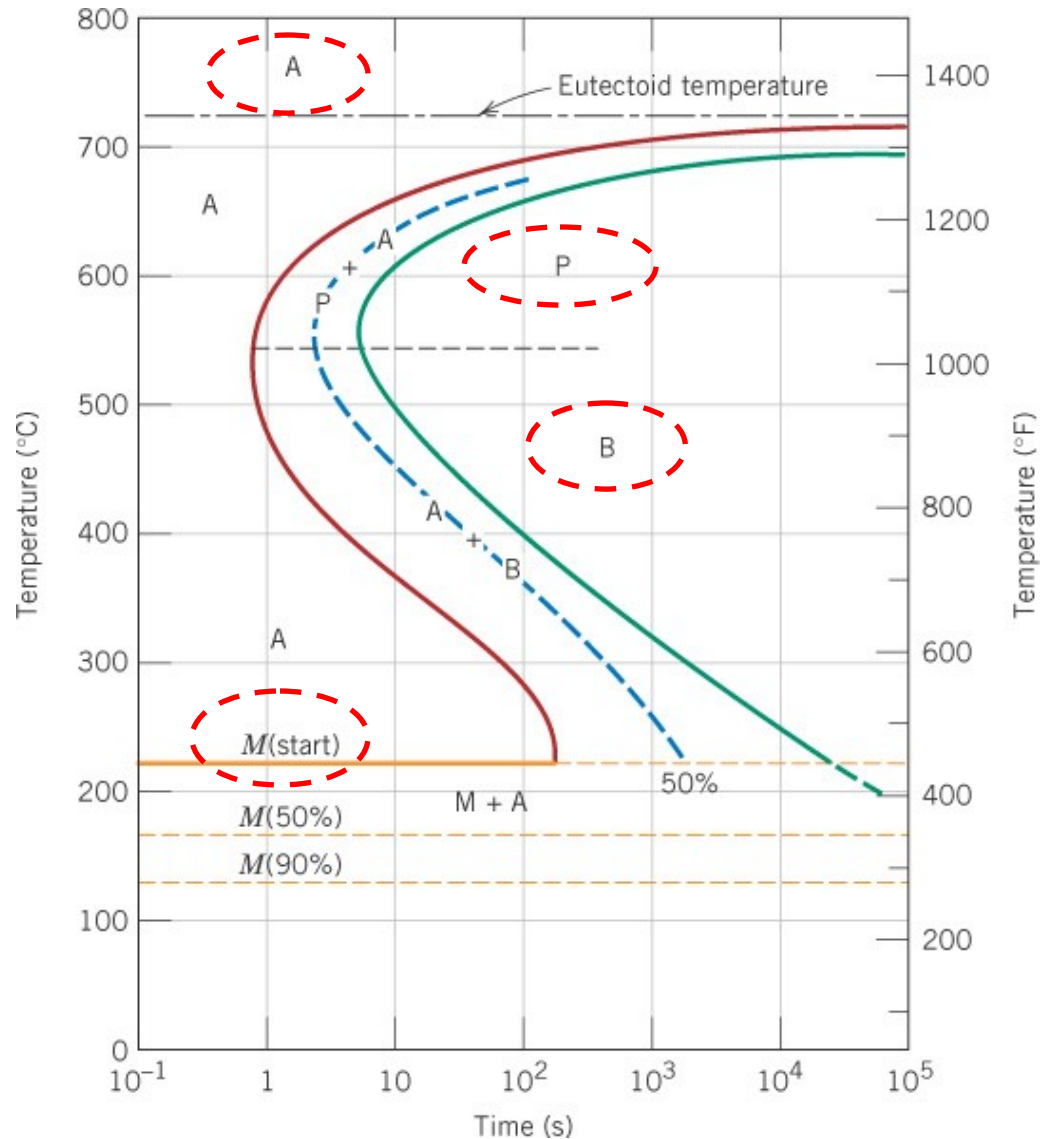

Temperature Transformation (TTT) Diagram: Unit 5

Example 1:

- Iron-carbon alloy with eutectoid composition.
- Specify the nature of the final microstructure (% bainite, martensite, pearlite etc) for the alloy that is subjected to the following time-temperature treatments:
- Alloy begins at 760°C and has been held long enough to achieve a complete and homogeneous austenitic structure.
- Treatment (a)
- Rapidly cool to 350 °C
- Hold for 10⁴ seconds
- Quench to room temperature

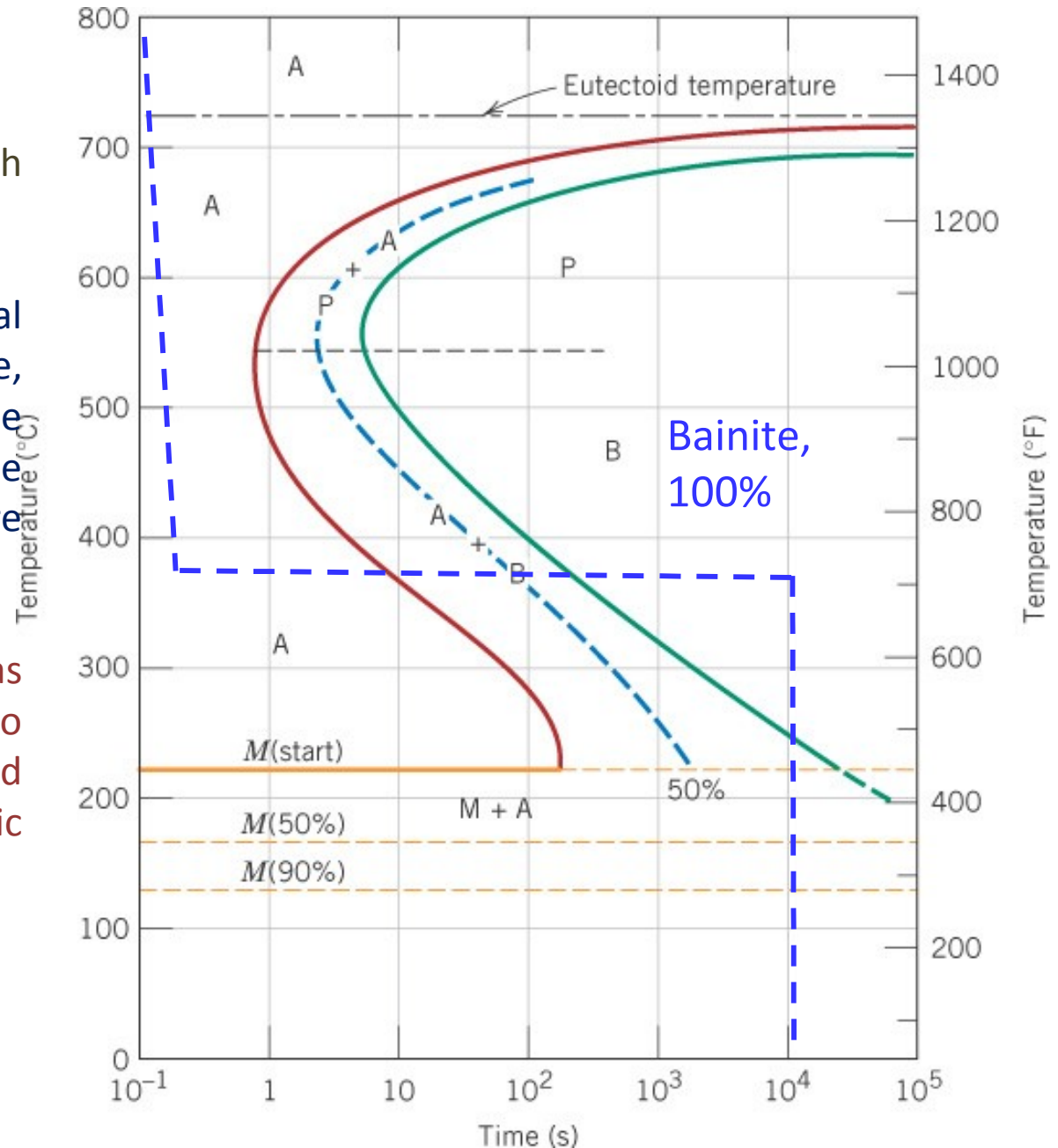

Temperature Transformation (TTT) Diagram: Unit 5

Example 2:

- Iron-carbon alloy with eutectoid composition.
- Specify the nature of the final microstructure (% bainite, martensite, pearlite etc) for the alloy that is subjected to the following time-temperature treatments:
- Alloy begins at 760°C and has been held long enough to achieve a complete and homogeneous austenitic structure.
- Treatment (b)
- Rapidly cool to 250 °C
- Hold for 100 seconds
- Quench to room temperature

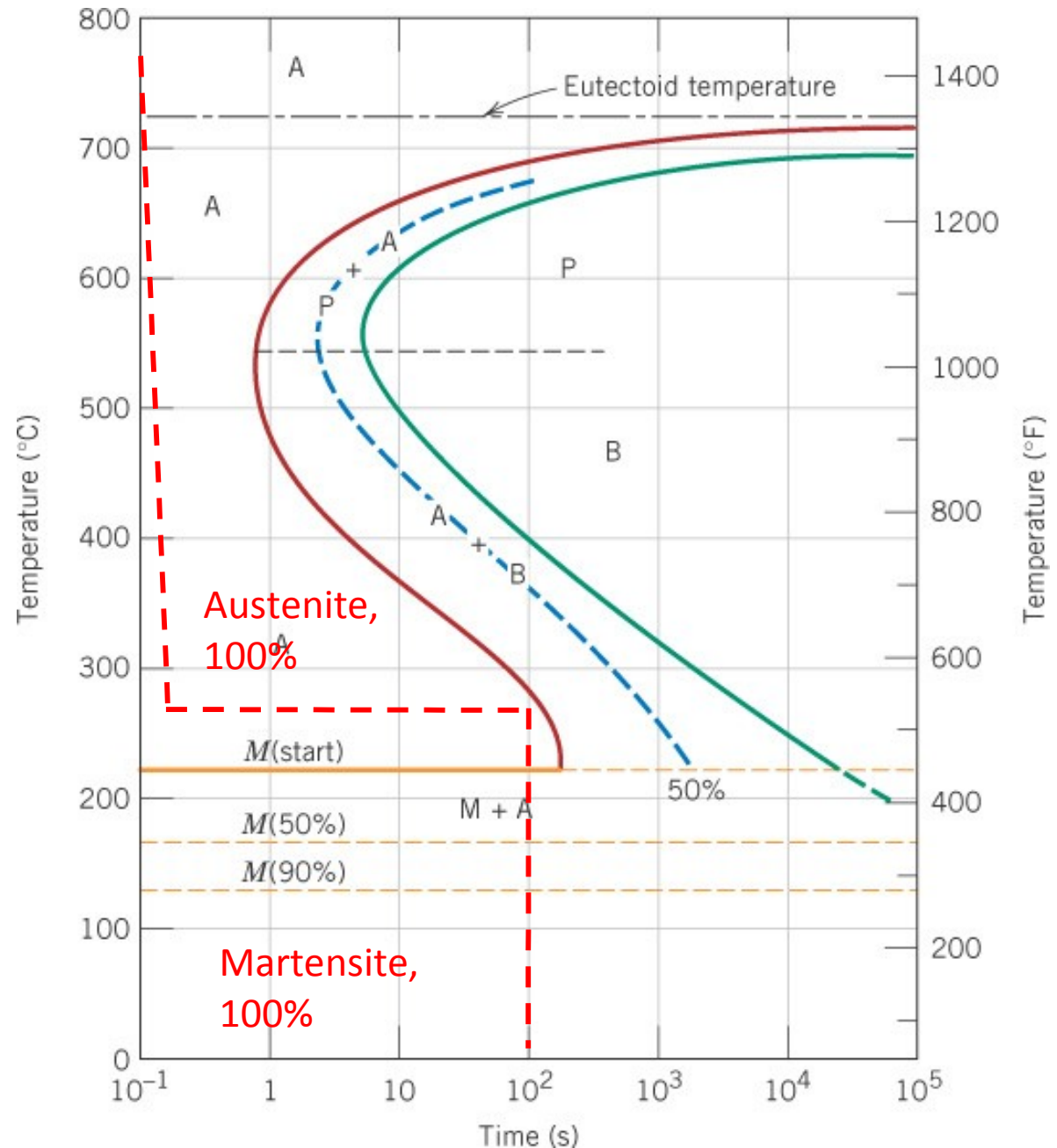

Temperature Transformation (TTT) Diagram: Unit 5

➤ Example 3:

➤ Iron-carbon alloy with eutectoid composition.

➤ Specify the nature of the final microstructure (% bainite, martensite, pearlite etc) for the alloy that is subjected to the following time-temperature treatments:

➤ Alloy begins at 760°C and has been held long enough to achieve a complete & homogeneous austenitic structure.

➤ Treatment (c)

➤ Rapidly cool to 650°C

➤ Hold for 20 seconds

➤ Rapidly cool to 400°C

➤ Hold for 10³ seconds

➤ Quench to room temperature

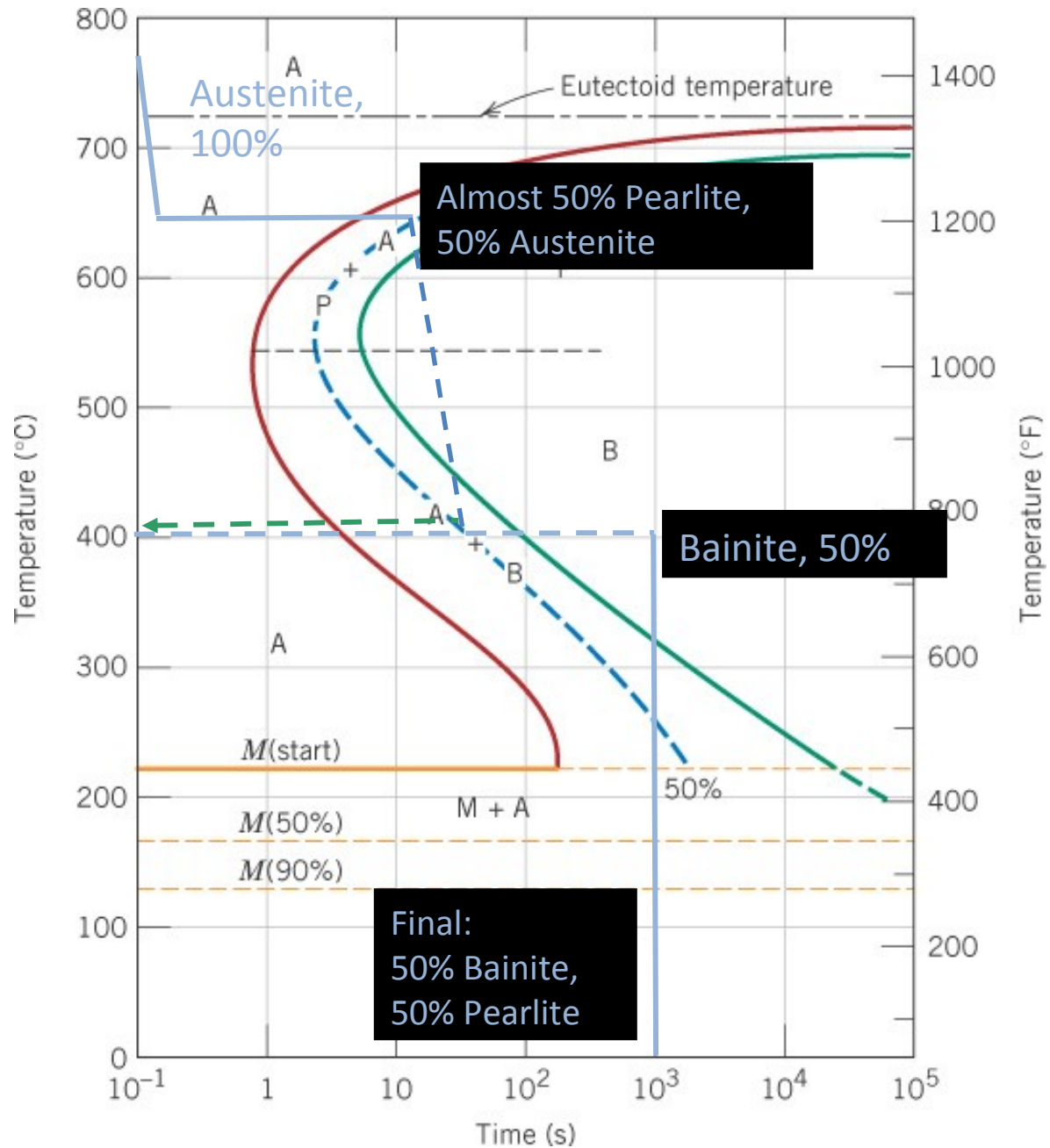

- Heat treating is a group of industrial and metalworking processes used to alter the physical, and sometimes chemical, properties of a material. The most common application is metallurgical.
- Heat treatment involves the use of heating or chilling, normally to extreme temperatures, to achieve a desired result such as hardening or softening of a material.

Heat treatment techniques include:

- Annealing,
- Case hardening,
- Precipitation strengthening,
- Tempering, and
- Quenching.

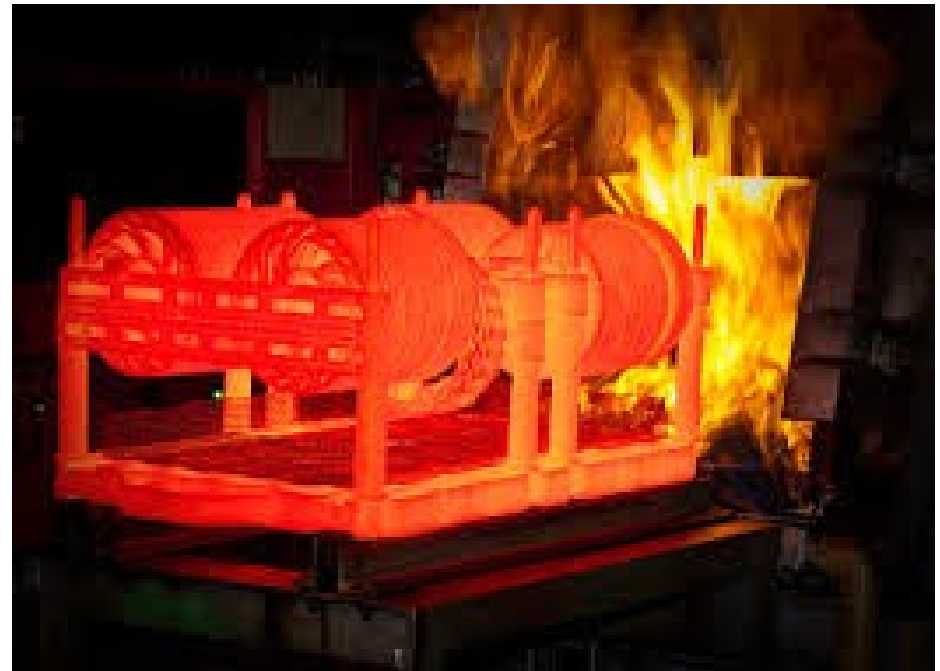

Annealing: Process Annealing

- In this treatment, steel (or any material) is heated to a temperature below the lower critical temperature, and is held at this temperature for sufficient time and then cooled.
- Cooling rate is of little importance as the process is being done at sub critical temperatures.
- The purpose of this treatment is to reduce hardness and to increase ductility of cold-worked steel so that further working may be carried easily.

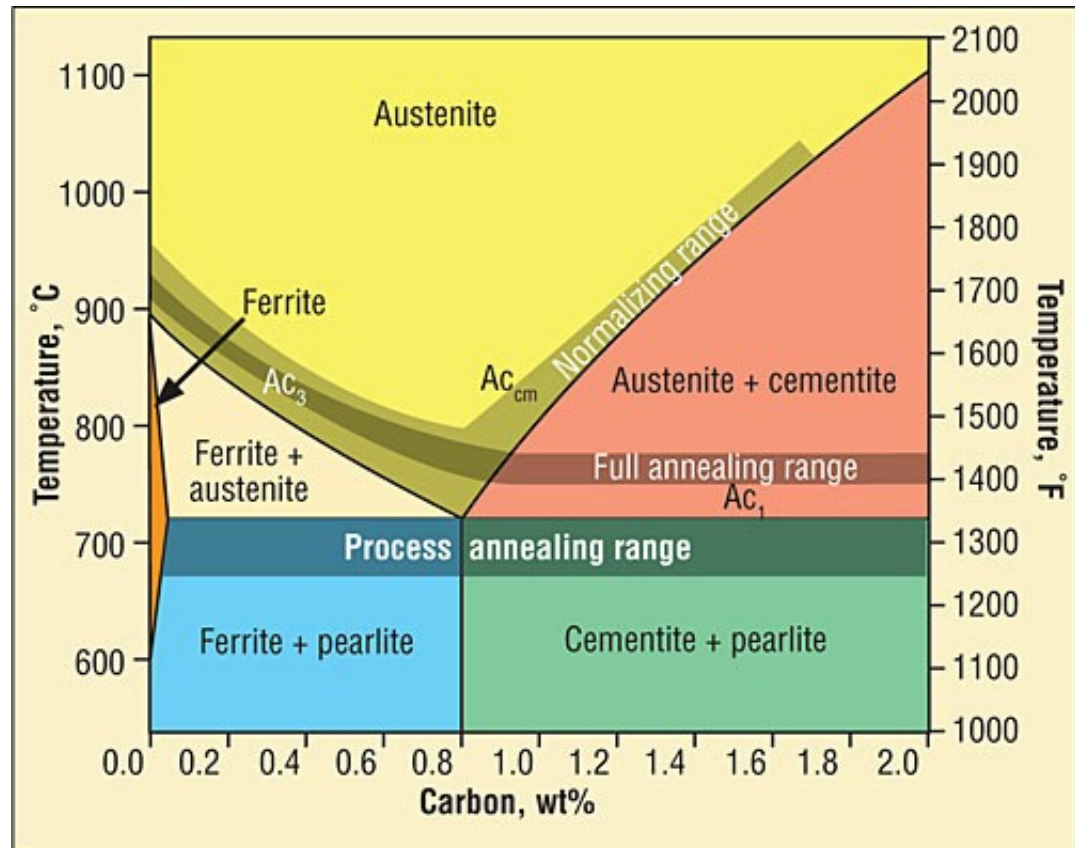

Annealing: Process Annealing

➤ This process is extensively used in the treatment of sheets and wires.

➤ Parts which are fabricated by cold forming such as stamping, extrusion, upsetting and drawing are frequently given this treatment as an intermediate step.

➤ Scaling or oxidation can be prevented or minimized by this process specially if annealed at lower temperatures or in non-oxidizing areas.

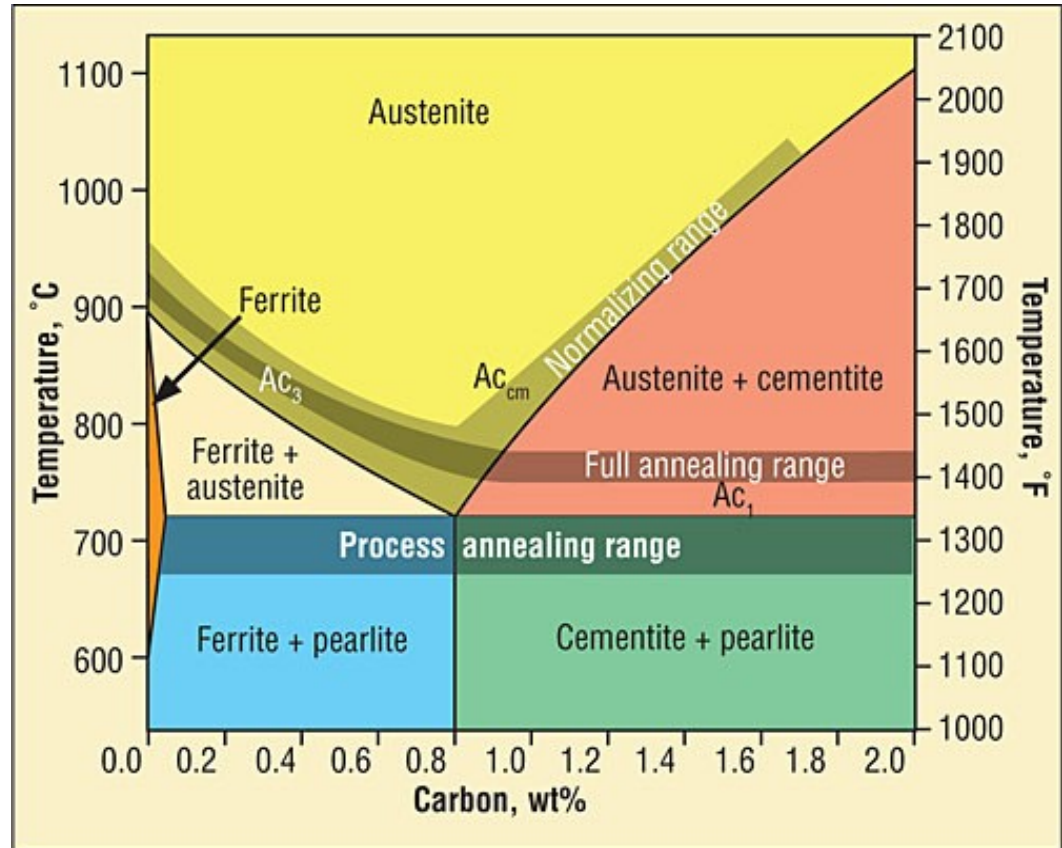

Annealing: Stress Relieving

- As the name suggests, this process is employed to relieve internal stresses. No microstructural changes occur during the process.
- Internal stresses are those stresses which can exist within a body in the absence of external forces. These are also known as residual stresses are locked-in stresses.
- These stresses are developed in operations like:

Solidification of castings, welding, machining, grinding, shot peening, surface hammering, cold working, case hardening, electroplated coatings, precipitation and phase transformation.

Annealing: Stress Relieving

- These internal stresses under certain conditions can have adverse effects: example: Steels with residual stresses under corrosive environment fail with stress corrosion cracking.
- These stresses also enhance the tendency of steels towards warpage and dimensional instability.
- Fatigue strength is reduced considerably when residual tensile stresses are present in steel.
- The problems associated with internal stresses are more difficult in brittle materials than in ductile materials.



Annealing: Stress Relieving

- The process of stress relieving consists of heating materials uniformly to a temperature below the lower critical temperature, holding at this temperature for sufficient time, followed by uniform cooling.
- Uniform cooling is of utmost importance as non-uniform cooling will itself result in the development of internal stresses. Thus the very purpose of stress relieving will be lost.
- Plain carbon steels and low alloy steels generally temperature is limited to 600 °C. Higher temperature is used for high alloy steels.
- The extent of the stresses relieved depend upon the temperature employed and holding time.

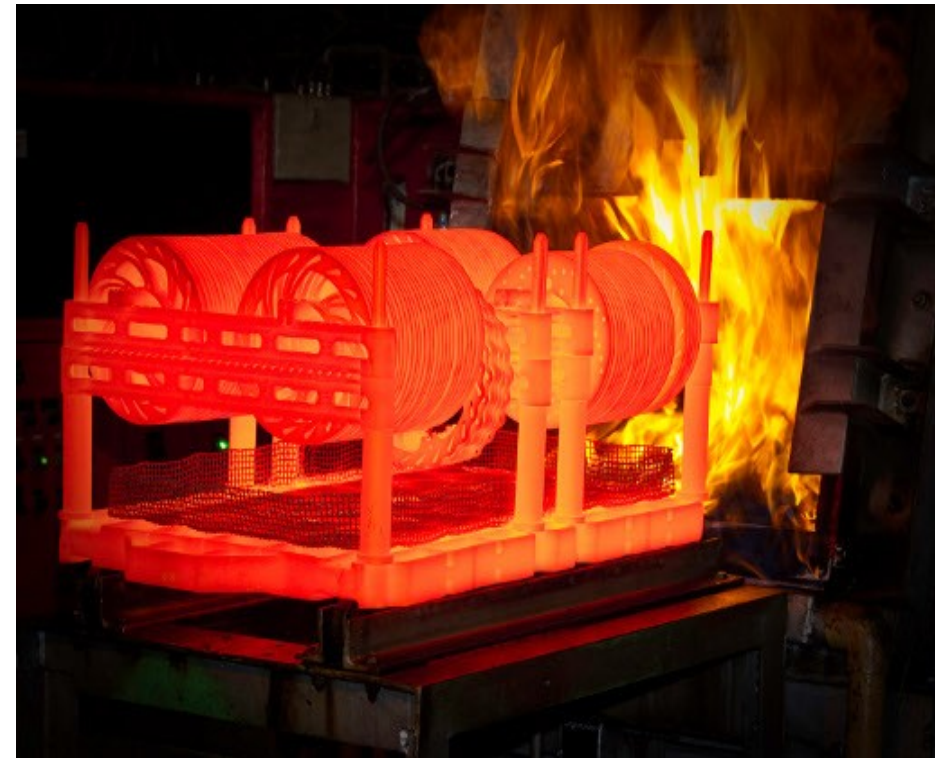

Annealing: Normalizing

➤ Normalizing is similar to full annealing, except steel is generally cooled in still air.

➤ The normalizing consists of heating steel to about 40-55 °C above critical temperature (Ac_3 or Ac_{cm}), and holding for proper item and then cooling in still air or slightly agitated air to room temperature.

➤ In some special cases, cooling rates can be controlled by either changing air temperature or air volume.

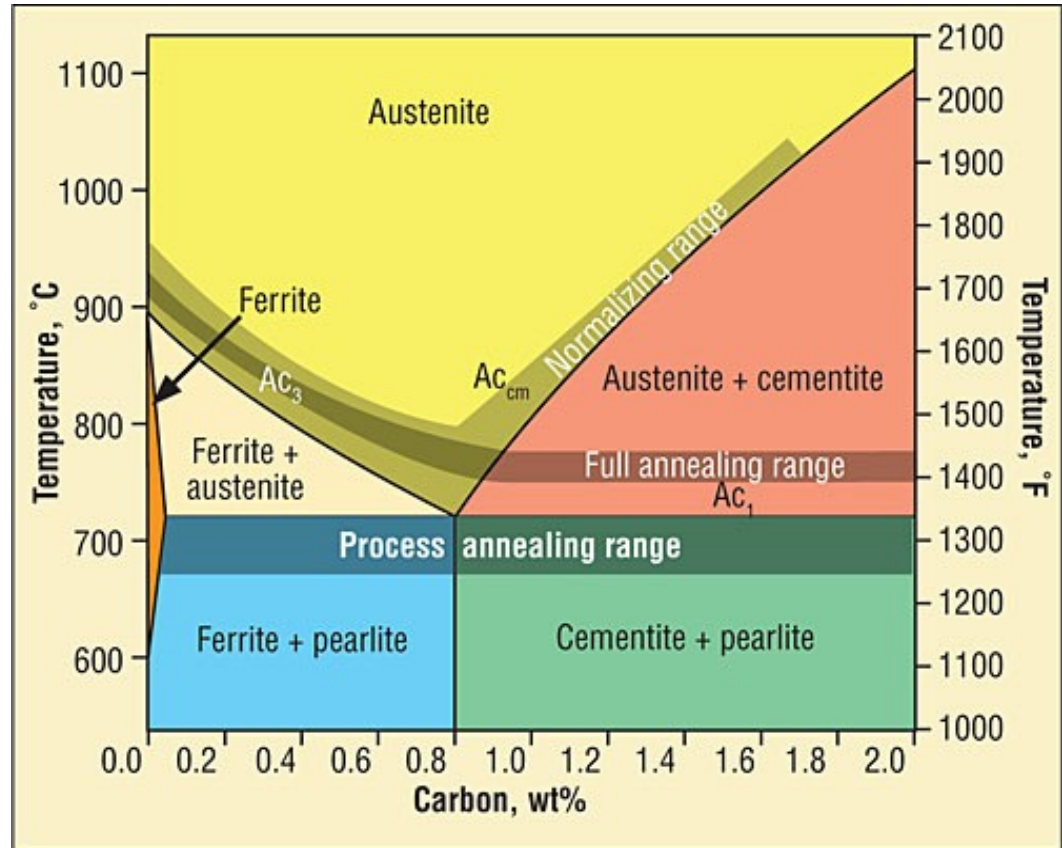

Annealing: Normalizing

➤ After normalizing, the resultant micro-structure should be pearlitic.

➤ Since the temperature involved in this process is more than that for annealing, the homogeneity of austenite increases and it results in better dispersion of ferrite and Cementite in the final structure.

➤ Results in better dispersion of ferrite and Cementite in the final structure.

➤ The grain size is finer in normalized structure than in annealed structure.

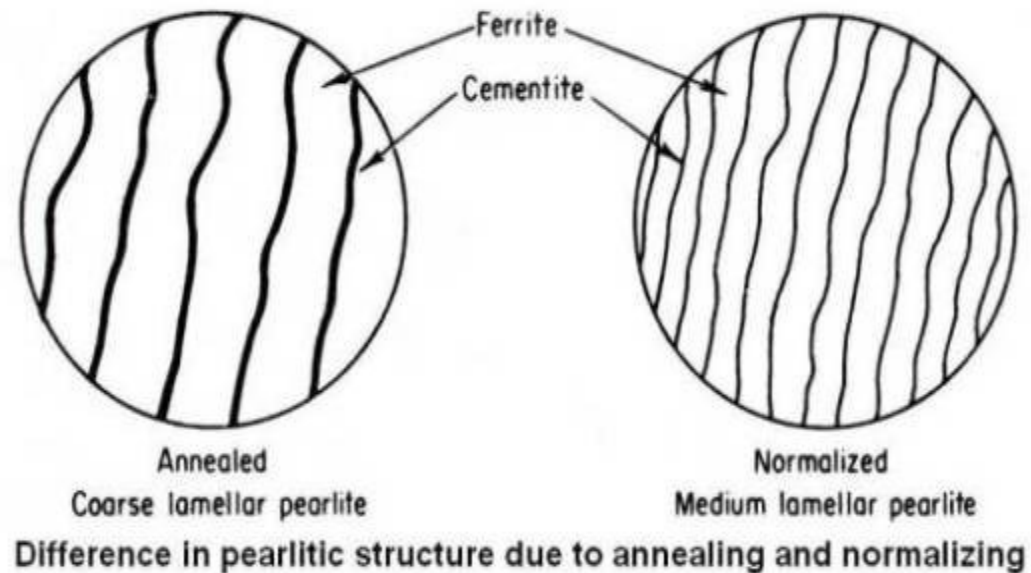

Annealing: Normalizing

➤ Normalized steels are generally stronger and harder than fully annealed steels.

➤ Steels are soft in annealed condition and tend to stick during machining. By normalizing, an optimum combination of strength and softness is achieved, which results in satisfactory level of Machinability in steels.

➤ Normalizing is the effective way to eliminate the carbide network.

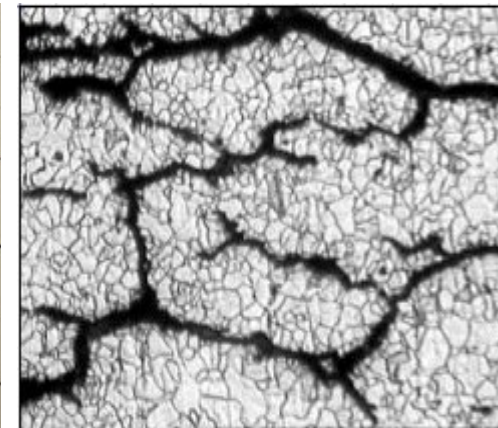
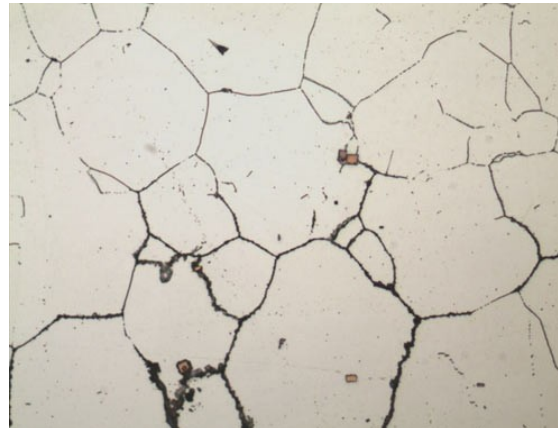

Annealing: Normalizing

➤ Normalized treatment is frequently applied to steel in order to achieve any one or more of the objectives, namely:

- To refine the grain structure,
- To obtain uniform structure,
- To decrease residual stresses,
- To improve Machinability.



Hardening:

➤ Hardening and Hardness are two very different things. One is a process of heat treatment and other is an extrinsic property of a material.

➤ Hardening is a heat treatment process in which steel is rapidly cooled from austenitising temperature. As a result of hardening, the hardness and wear resistance of steel are improved.

➤ Hardening treatment generally consists of heating to hardening temperature, holding at that temperature, followed by rapid cooling such as quenching in oil or water or salt baths.

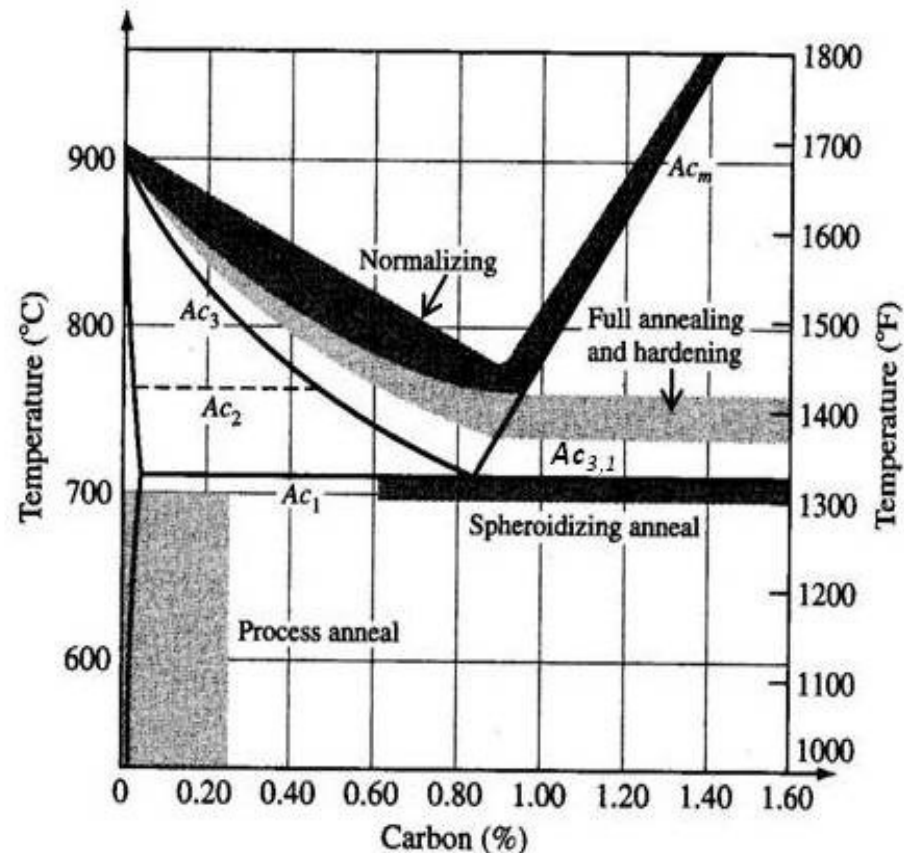

Temperature Range for Heat Treatment of Carbon Steels

Hardening:

- The high hardness developed by this process is due to the phase transformation accompanying rapid cooling. Rapid cooling results in the transformation of austenite at considerably low temperature into non-equilibrium products.
- The hardening temperature depends on chemical composition. For plain carbon steels, it depends on the carbon content alone. Hypoeutectoid steels are heated to about 30 – 50 °C above the upper critical temperature, whereas eutectoid and hyper eutectoid steels are heated to about 30 – 50 °C above lower critical temperature.
- Ferrite and pearlite transform to austenite at hardening temperature for hypoeutectoid steel. This austenite transforms to martensite on rapid quenching from hardening temperature. The presence of martensite accounts for high hardness of quenched steel.

Hardening:

➤ Hardening is applied to cutting tools and machine parts where high hardness and wear resistance are important.

➤ The Process Variables:

Hardening Temperature: The steel should be heat treated to optimum austenitising temperature. A lower temperature results lower hardness due to incomplete transformation to austenite. If this temperature is too high will also results lower hardness due to a coarse grained structure.

Soaking Time: Soaking time at hardening temperature should be long enough to transform homogenous austenite structure. Soaking time increases with increase in section thickness and the amount of alloying element.

Delay in quenching: After soaking, the steel is immediately quenched. Delay in quenching may reduce hardness due to partial transformation of austenite.

Type of quenching medium also has a profound effect, which will be discussed briefly.²³

Hardening:

➤ The main purpose of hardening tool steel is to develop high hardness. This enables tool steel to cut other metals. High hardness developed by this process also improves wear resistance. Gears, shafts and bearings. Tensile strength and yield strength are improved considerably by hardening structural steels.

➤ Because of rapid cooling, high internal stresses are developed in the hardened steel. Hence these steels are generally brittle. Hardening in general is followed by another treatment known as tempering which reduces internal stresses and makes the hardened steel relatively stable,

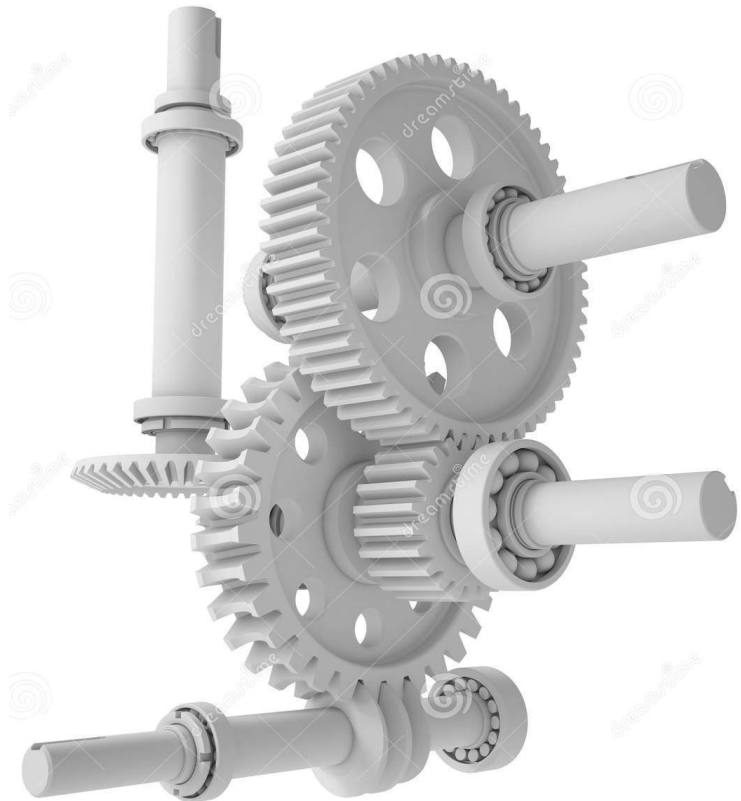

Tempering:

➤ Hardened steels are so brittle that even a small impact will cause fracture. Toughness of such a steel can be improved by tempering. However there is small reduction in strength and hardness.

➤ Tempering is a sub-critical heat treatment process used to improve the toughness of hardened steel.

➤ Tempering consists of reheating of hardened steel to a temperature below Lower critical temperature and is held for a period of time, and then slowly cooled in air to room temperature.

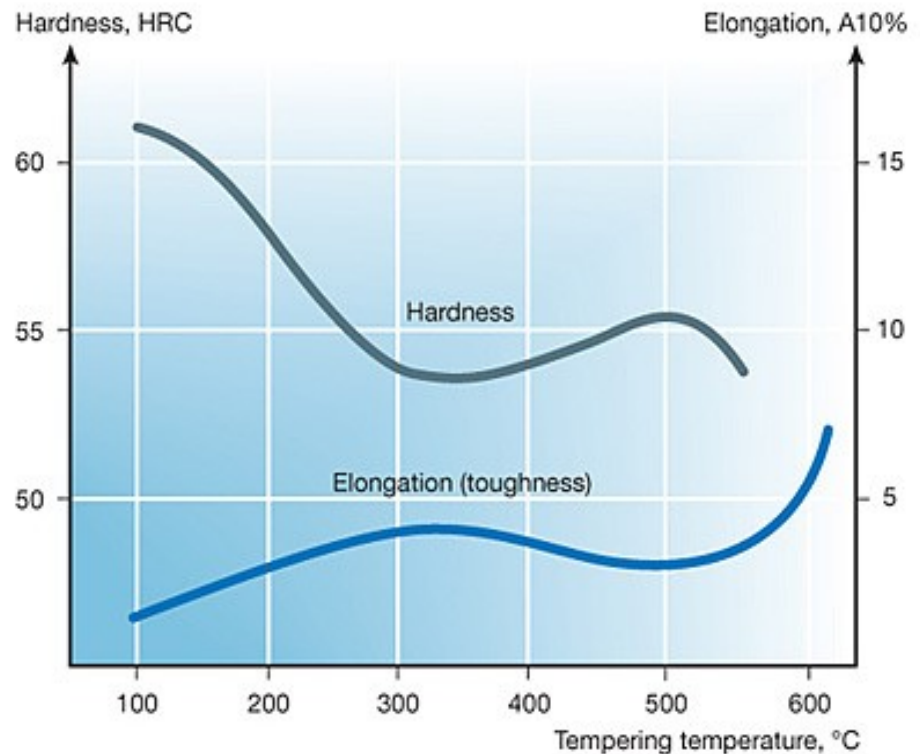

Tempering:

➤ At tempering temperature, carbon atoms diffuse out and form fine cementite and softer ferrite structure left behind. Thus the structure of tempered steel consists of ferrite and fine cementite.

➤ Thus tempering allows to precipitate carbon as very fine carbide and allow the microstructure to return to BCC

➤ The temperatures are related to the function of the parts. Cutting tools are tempered between 230 – 300 °C. If greater ductility and toughness are desired as in case of shafts and high strength bolts, the steel is tempered in the range of 300 – 600 °C.

Toughened Microstructure



Tempered Microstructure

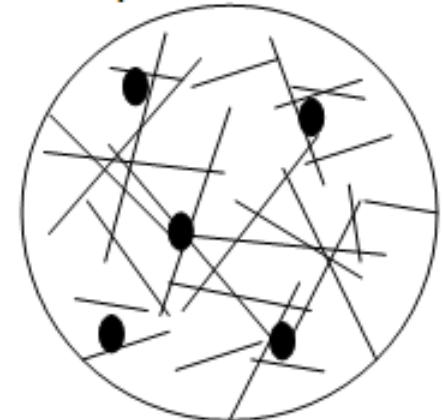

Tempering:

➤ Tempering temperatures are usually identified by the colour. Tempering temperatures for tools and shafts along with temper colors.

➤ Depending on temperatures, tempering processes can be classified as:

1) Low- temperature tempering (150 – 250 °C),

2) Medium – temperature tempering (350 – 450 °C),

3) High – temperature tempering (500 – 650 °C).

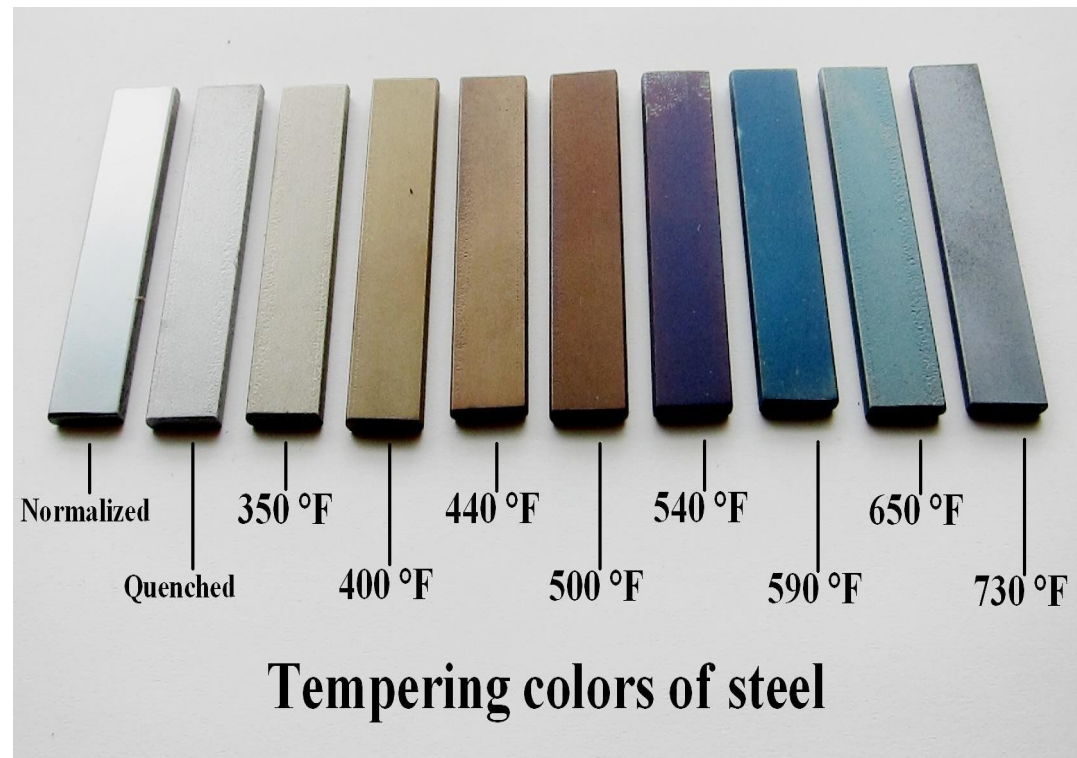

Heat Treatment

Tempering:

➤ Tempering temperatures are usually identified by the colour. Tempering temperatures for tools and shafts along with temper colors.

°F	tempering colours	°C
630	Grey Green	330
610	Grey Blue	320
590	Light Blue	310
570	Wedgewood Blue	300
550	Dark Blue	290
530	Violet	280
520	Purple	270
500	Red Brown	260
480	Yellow Brown	250
460	Dark Yellow	240
450	Yellow	230
430	Straw	220
410	Light Yellow	210
°F		°C

TEMPERING COLOUR	TEMPERATURE °C	TEMPERING COLOUR
PALE YELLOW	230	LATHE TOOLS FOR BRASS
DARK YELLOW	240	LATHE TOOLS FOR MILD STEEL
BROWN	250	WOOD TURNING TOOLS
BROWN/PURPLE	260	WOOD WORKING TOOLS
PURPLE	270	AXES
DARK PURPLE	280	COLD FORGING TOOLS
BLUE	300	SPRINGS

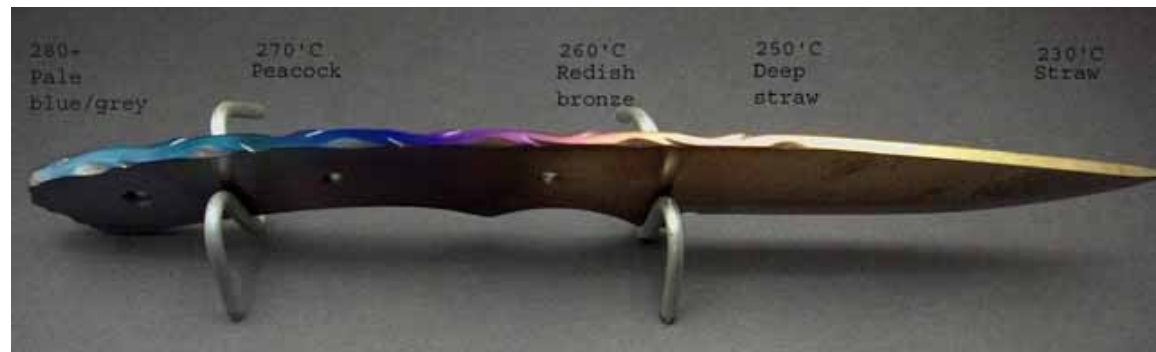

Heat Treatment

Hardenability:

➤ The responsibility of a steel to a given hardening treatment is indicated by the property known as Hardenability.

➤ It is an index of the depth to which the martensite can be formed in a given steel as a result of a given hardening treatment.

➤ The term Hardenability is used to measure the depth of hardness achieved i.e. martensite introduced into the steel section by quenching the steel from austenite state.

➤ Greater the depth of hardness below the surface, higher will be the Hardenability of steel.

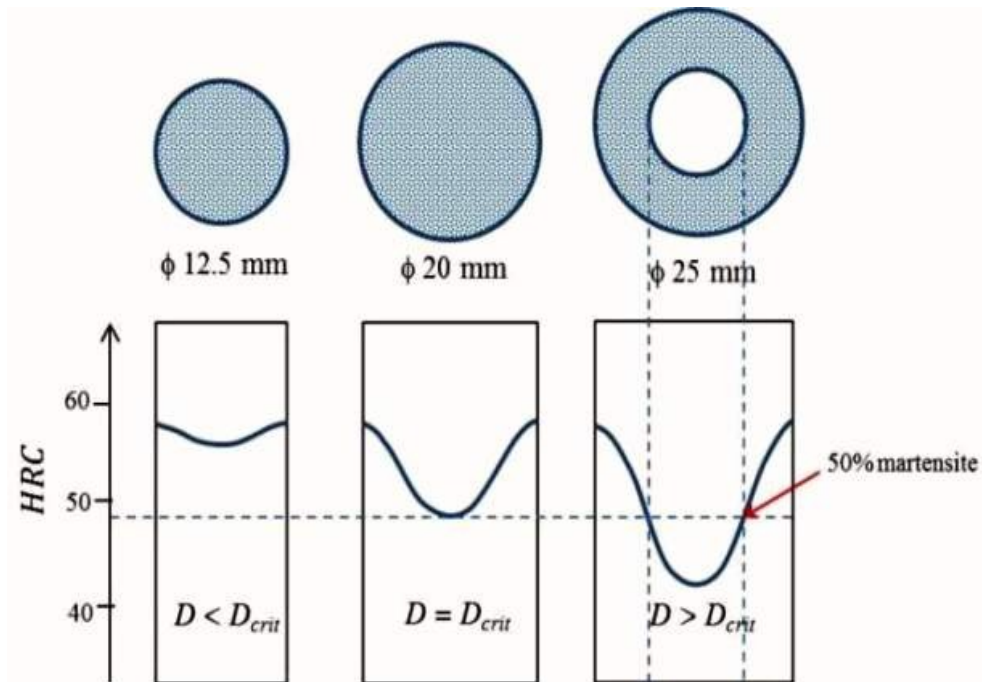

Heat Treatment

Hardenability:

- Hardenability of steel depends on composition of steel, method of quenching and section of steel.
- The addition of alloying elements in steel decreases the critical cooling rate. Thus the Hardenability of alloy steels is more than that of the carbon steels.
- While in the oil quenching, the cooling rates are lower than water quenching and thus the hardness values are lower in case of oil quenched steels.
- The larger section shows lower Hardenability because of their increase mass results in a lower overall rate of cooling.

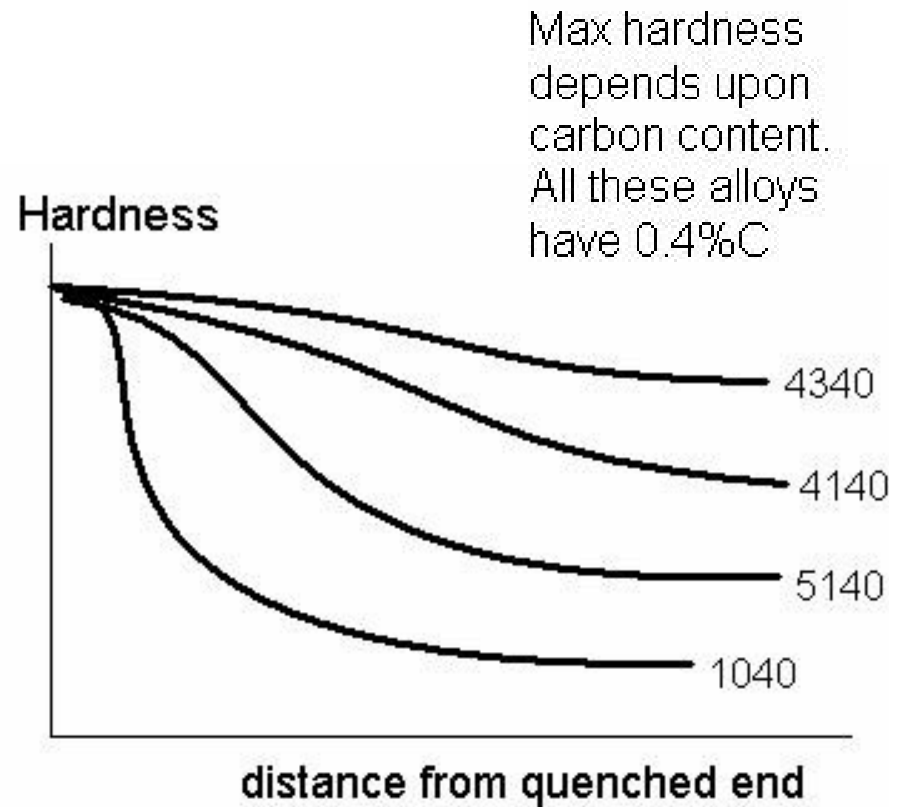

Hardenability: Jominy End Quench Test

➤ The most simple and convenient method of determining the Hardenability is the Jominy End Quench Test.

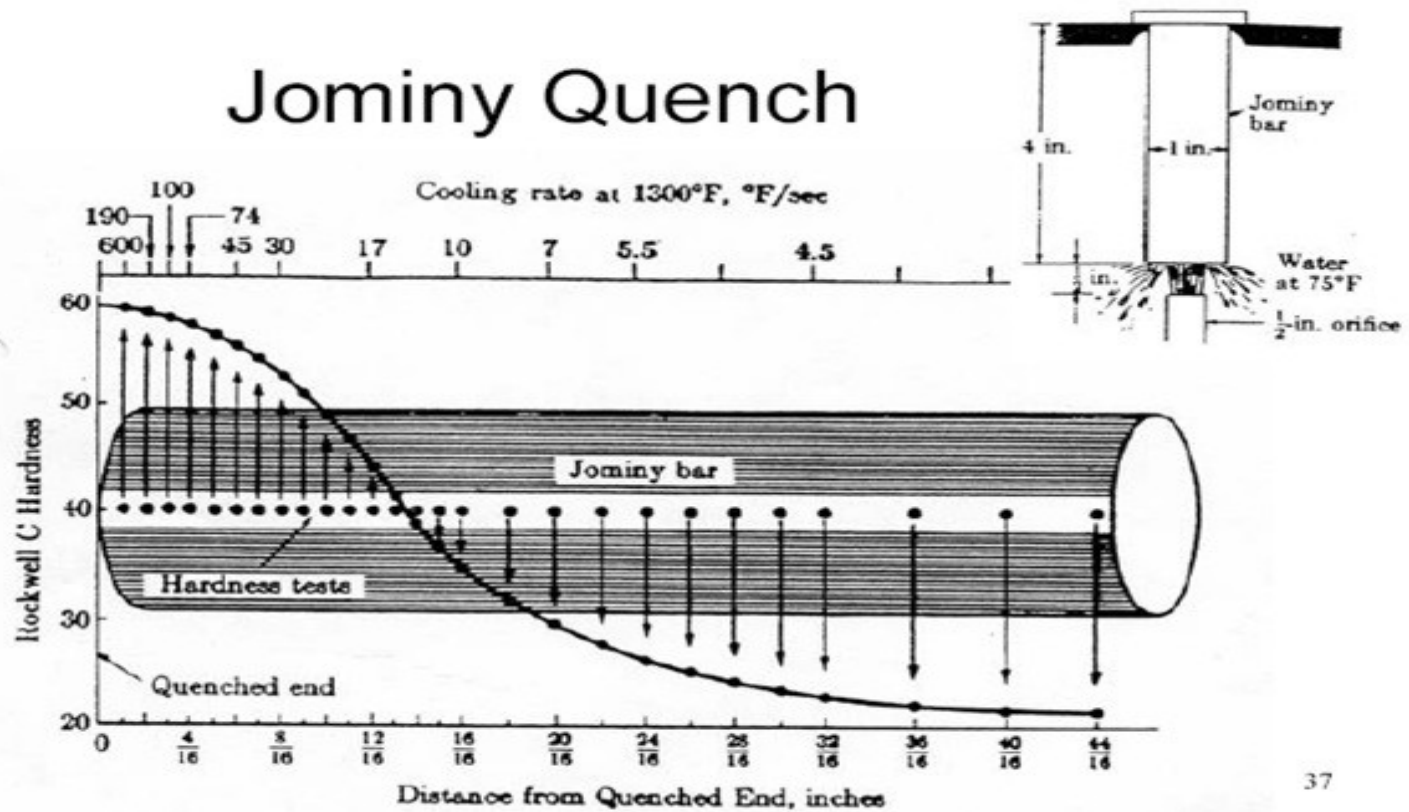

37

➤ The Jominy test involves heating a standard test piece of diameter 25 mm and length 100 mm to the austenite state, fixing it to a frame in a vertical position and then quenching the lower end by means of a jet of water.

31

Hardenability: Jominy End Quench Test

- The mode of quenching results in different rate of cooling along the length of the test piece.
- After a quenching, a flat of 0.38 mm deep is ground along one side of the test piece, and hardness measurements are made along the length of the test piece.
- A bar of steel having good Hardenability shows higher hardness readings for greater distance from the quenched end.

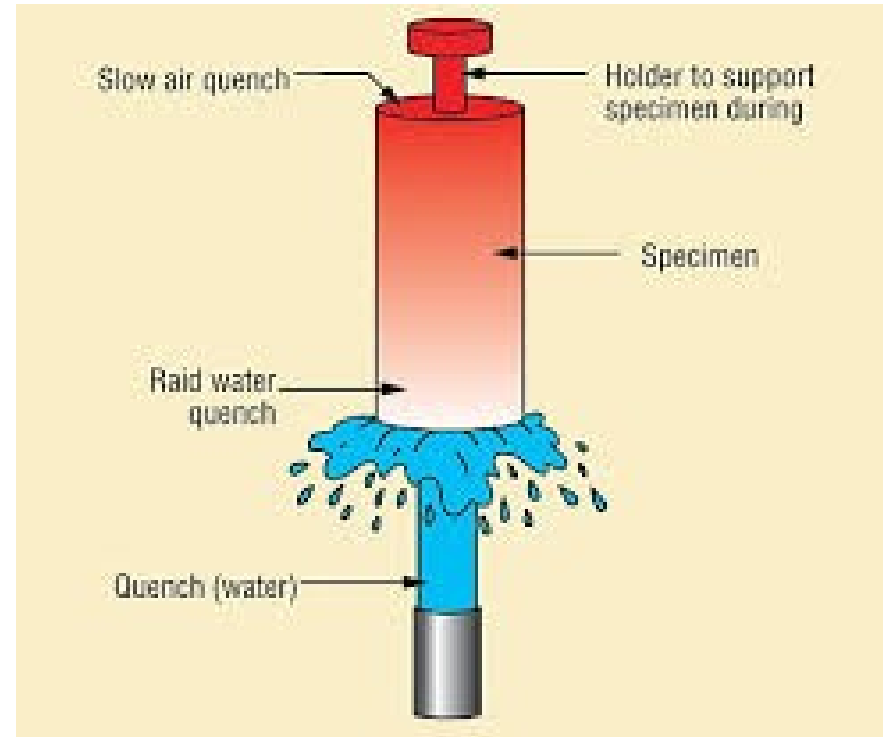

Quenching:

➤ Quenching is a process of rapid cooling of materials from high temperature to room temperature or even lower. In steels quenching results in transformation of austenite to martensite (a non-equilibrium constituent).

➤ During cooling, heat must be extracted at a very fast rate from the steel piece. This is possible only when a steel piece is allowed to come in contact with some medium which can absorb heat from the steel piece within a short period.

➤ Under ideal conditions, all the heat absorbed by the medium should be rejected to the surroundings immediately.



Quenching:

➤ The removal of heat during quenching is complex in the sense that heat is removed in three stages.

- 1) Vapor Blanket,
- 2) Nucleate Boiling,
- 3) Convection.

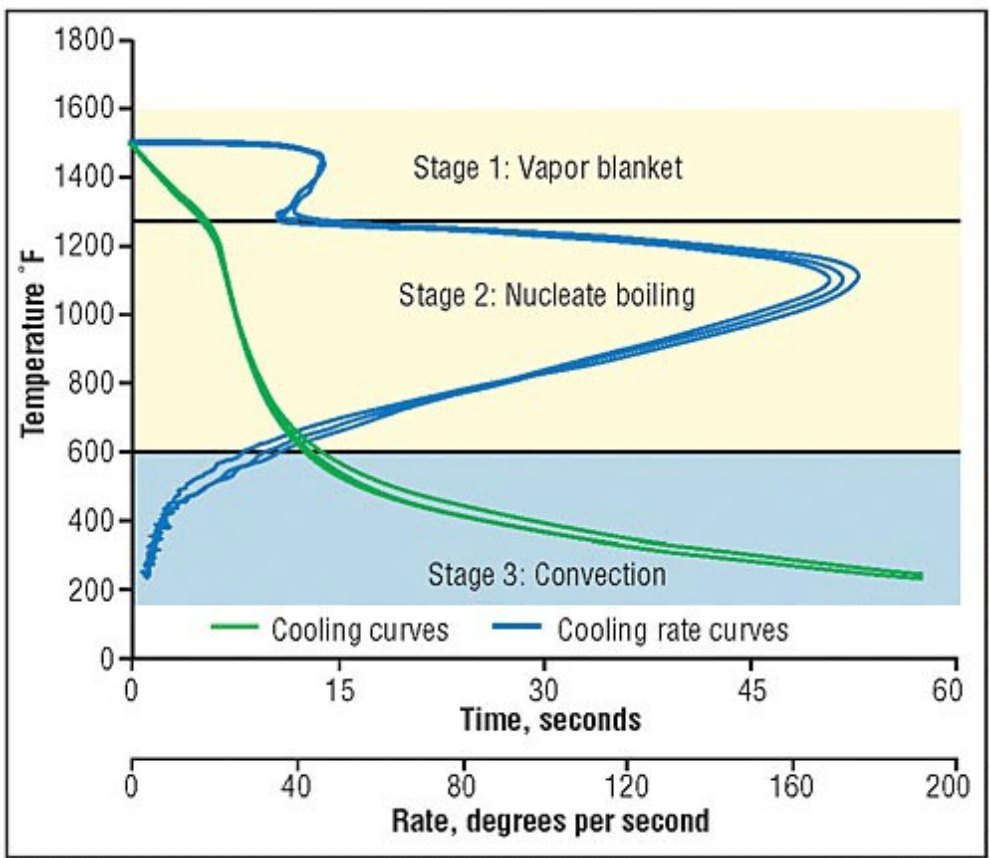

Quenching:

➤ Vapor Blanket (stage 1)

As soon as the work-piece comes into contact with a liquid coolant (quenchant), the surrounding quenchant layer is instantaneously heated up to the boiling point of the quenchant and gets vaporized due to the high temperature of the work-piece.

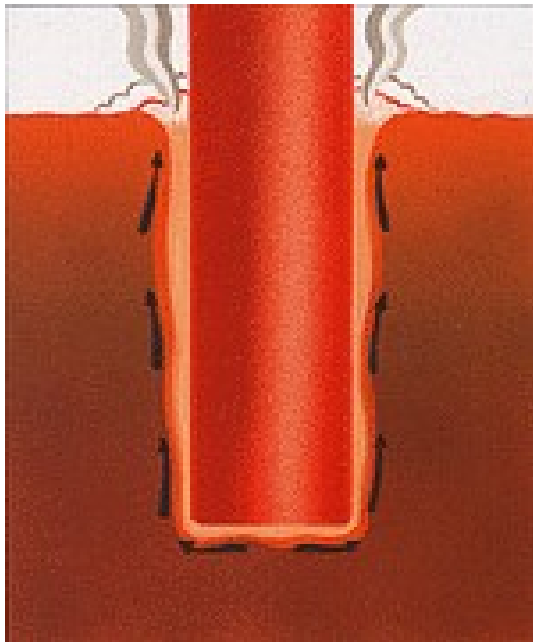

➤ This acts as an insulator, preventing the quenching oil from contacting the metal surface. As a consequence, the rate of cooling during this stage is slow.

➤ At this stage the work piece is cooled only by conduction and radiation through the vapor film.

➤ Only the surface is cooled considerably prior to the formation of vapor envelop.

Quenching:

➤ Nucleate Boiling (stage 2)

This second stage is also called as transport cooling stage or liquid boiling stage. The temperature of the work-piece comes down, through very slowly and the vapor blanket is no longer stable and collapses.

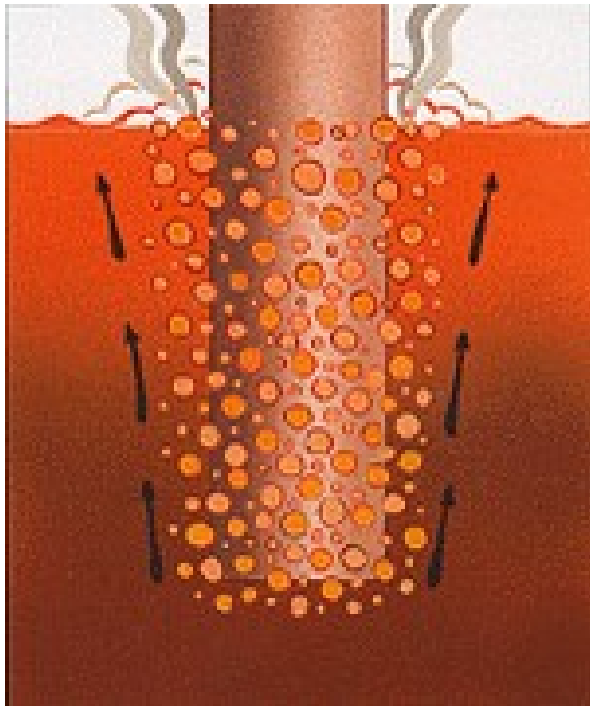

➤ Metal surface comes into contact with the liquid/quenchant. Violent boiling quickly removes heat from the quenched component while forming bubbles and being pushed away, resulting in the cooler fluid coming into contact with the work piece.

➤ This happens till the temperature of the work piece comes down to the boiling point of the liquid.

➤ Maximum cooling rate is achieved during this stage.

Quenching:

➤ Convection (stage 3)

The third stage is called as the liquid cooling stage or the convection stage.

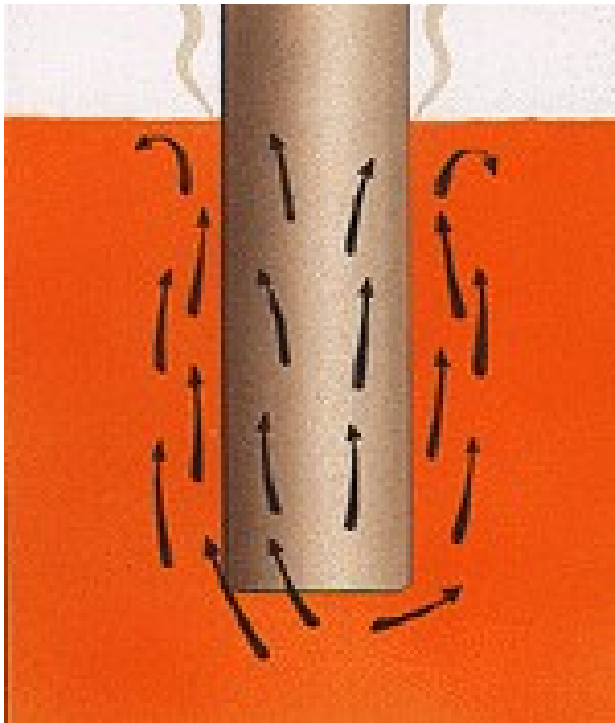

- It starts when the temperature of the surface becomes equal to the boiling point of the quenchant.
- Cooling at this stage takes place via conduction and convection processes.
- The rate of cooling is the slowest at this stage.

Quenching: Effect of Quenching Medium

- Quenching medium has the profound effect on the final phase of the material. Quenching medium is directly related to the rate of the cooling of the material.
- Some of the widely employed quenching media are water, aqueous solutions, oils (mineral, vegetable and even animal oils), molten salts and air.



Quenching: Effect of Quenching Medium (Water)

- Water has maximum cooling rate amongst all common quenchants except few aqueous solutions.
- It is very cheap and easily disposed off compared to other quenchants.
- Hence water is used for carbon steels, alloy steels and non-ferrous alloys.
- The layer of scale formed on the surface during heating is also broken by water quenching, thus eliminating an additional process of surface cooling.



Quenching: Effect of Quenching Medium

- Most of the Oils used as quenchants are mineral oils. These are in general paraffin based and do not possess any fatty oils.
- Quenching in oil provides slower cooling rates as compared to those achieved by water quenching.
- The slower cooling rate reduces the possibility of hardening defects.
- The temperature difference between core and the case of work piece is less for oil quenching than for water quenching.



Heat Treatment

Quenching: Effect of Quenching Medium (AIR)

- Many alloy steels are capable of getting hardened by cooling either in still air or in a blast of air.
- Such steels are popularly known as air hardening steels.
- These steels are almost free from distortion problem. However, the problem of oxidation during cooling (quenching) may be encountered in practice. Many grades of tool steels are subjected to air hardening.
- Cooling rates can be improved by mixing air and water.

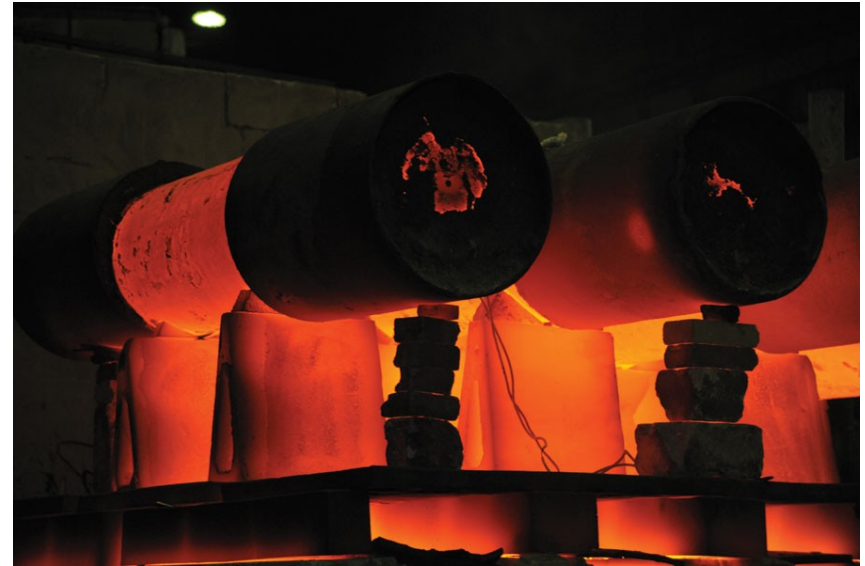

Quenching: Effect of Quenching Medium :

- Just the drastic water quench generates a fully martensite structure.
- Although quenched in oil the austensite converts into suitably fine pearlite.
- Accurate pearlite also results if the austenised eutectoid steel is air-cooled.
- Though, if allowed to cool in furnace coarse pearlite is appearance.

Cooling Media	Structure	UTS (N/mm ²)	Y. S. (N/mm ²)	Hardness (Rc)	Elongation % (50 mm g. L)
Water	Martensite	1700	-	65	Low
Oil	Troostite	1100	550	35	5
Air	Fine pearlite	850	270	25	8
Furnace	Coarse pearlite	520	140	15	12

Heat Treatment

Quenching: Effect of Quenching Medium

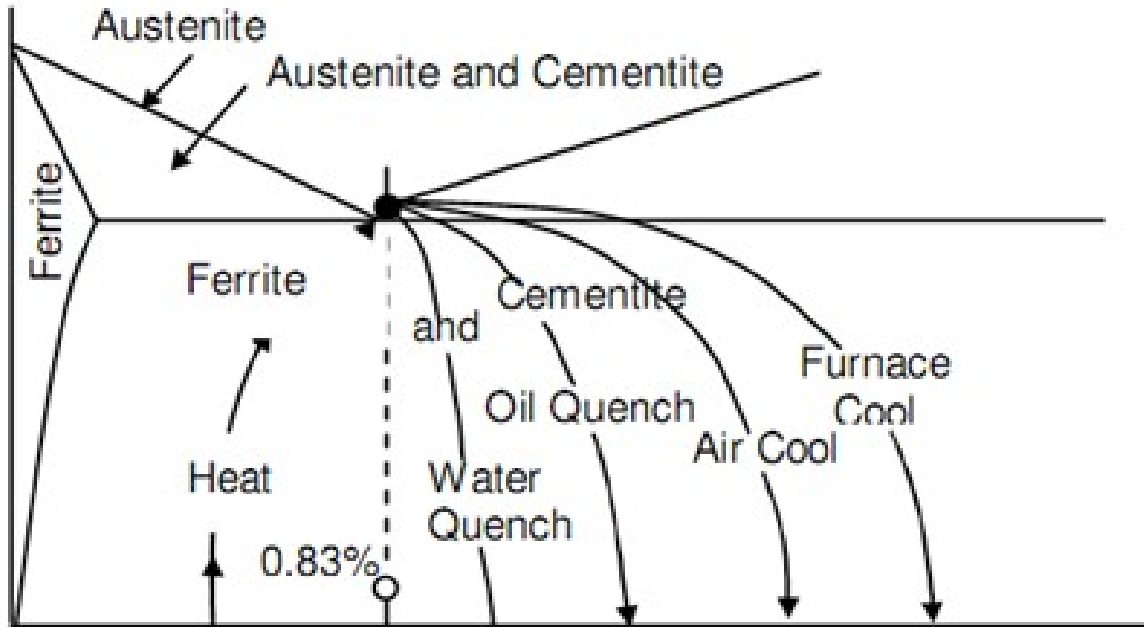

Eutectoid



Martensite (Black)
Cementite (White)



Very Fine Pearlite



Fine Pearlite

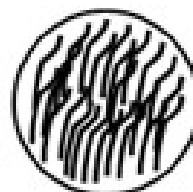

Coarse Pearlite

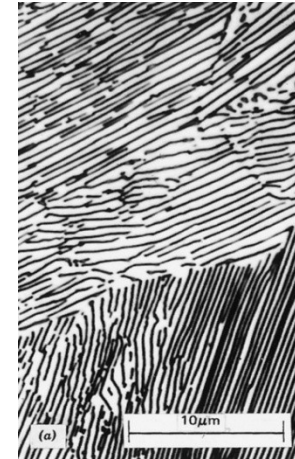

Coarse Pearlite

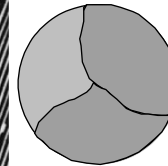

- Smaller ΔT : colonies are larger

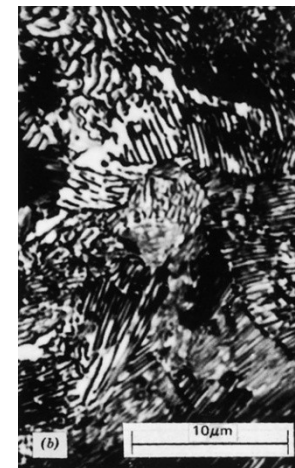

Fine Pearlite

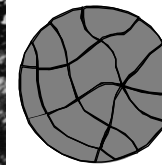

- Larger ΔT : colonies are smaller

Figure: Microstructure resulting from Different Cooling Rates Applied to Austenitized Samples of Eutectoid Steel

Surface Hardening:

➤ In many situations hard and wear resistance surface is required with the tough core. Because of tough core the components can withstand impact load. The typical applications requiring these conditions include gear teeth, cams shafts, bearings, crank pins, clutch plate, tools and dies.

➤ The combination of the these properties can be achieved by the following methods:

➤ 1. Hardening and tempering the surface layers (surface hardening)

(i) Flame Hardening (ii) Induction Hardening

➤ 2. Changing the composition at surface layers (chemical heat treatment or case hardening)

(i) Carburising (ii) Nitriding (iii) Carburising and Cyaniding

Heat Treatment

Surface Hardening: Flame Hardening

- The flame hardening involves heating the surface of a steel to a temperature above upper critical point ($850\text{ }^{\circ}\text{C}$) with a oxyacetylene flame and then immediately quenched the surface with cold water.
- Heating transforms the structure of surface layers to austenite, and the quenching changes it to martensite.

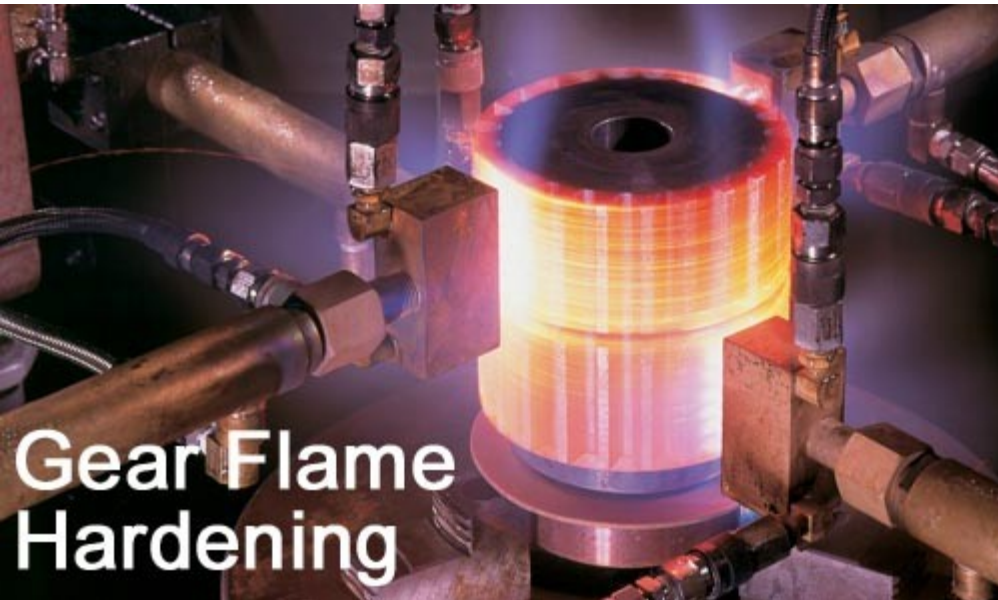

Surface Hardening: Flame Hardening

- The surface layers are hardened to about 50 – 60 HRC. It is less expensive and can be easily adopted for large and complex shapes.
- Flame hardened parts must be tempered after hardening. The tempering temperature depends on the alloy composition and desired hardness.

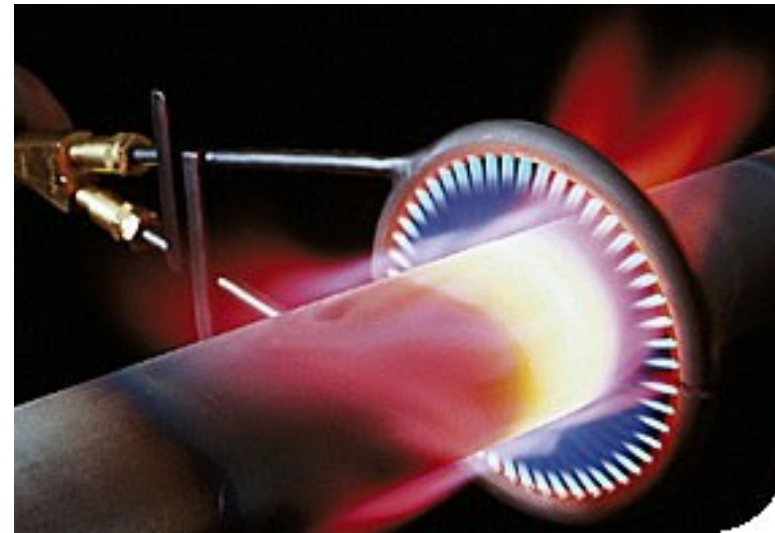

- The flame hardening methods are suitable for the steels with carbon contents ranging from 0.40 to 0.95% and low alloy steels.

Heat Treatment

Surface Hardening: Induction Hardening

- Induction hardening involves placing the steel components within a coil through which high frequency current is passed. The current in the coil induce eddy current in the surface layers, and heat the surface layers upto austenite state.
- Then the surface is immediately quenched with the cold water to transfer the austenite to martensite. The principle of induction hardening is:

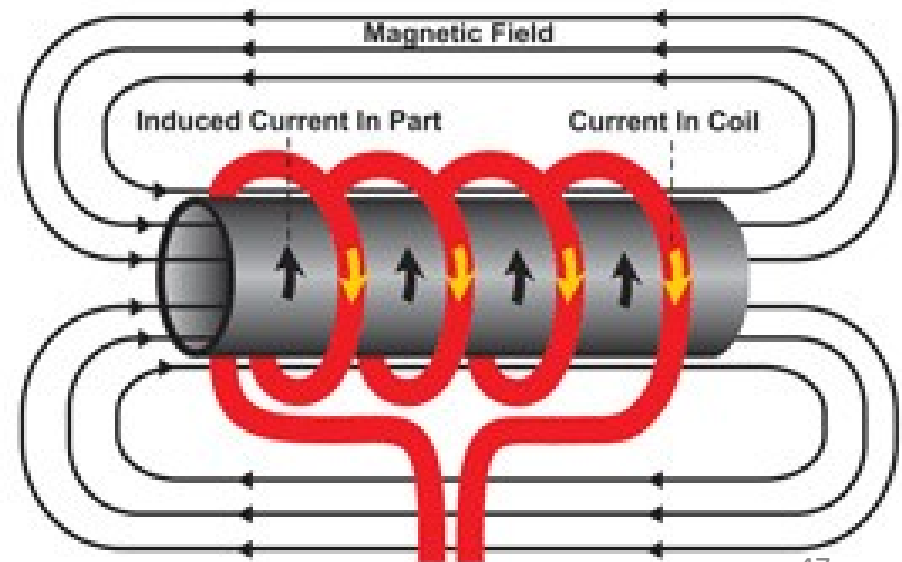
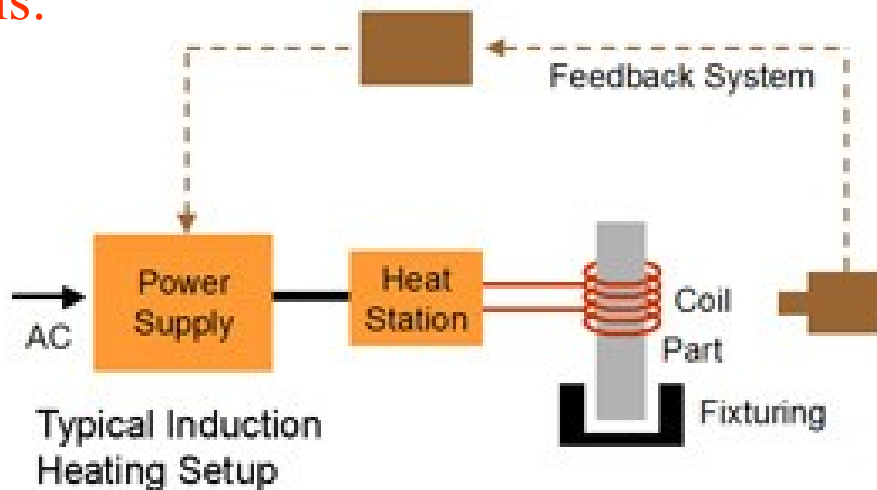

Surface Hardening: Induction Hardening

- Advantages of induction hardening over flame hardening is its speed and ability to harden small parts; but it is expensive. Like flame hardening, it is suitable for medium carbon and low alloy steels.
- Typical applications for induction hardening are crank shafts, cam shafts, connecting rods, gears and cylinders.



Heat Treatment

Surface Hardening: Carburising

- Carburising is carried out on steels containing carbon less than 0.2%. It involves increasing the carbon contents on the surface layers upto 0.7 to 0.8%.
- In this process, the steel is heated in contact with carbonaceous material from which it absorbs carbon. This method is mostly used for securing hard and wear resistance surface with tough core carburising is used for gears, cams, bearings and clutch plates.

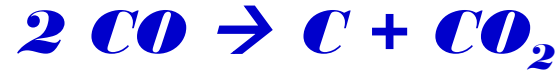

Heat Treatment

Surface Hardening: Carburising

➤ The Following methods are used to diffuse carbon into surface layers:

- 1) Pack (solid) Carburising,
- 2) Gas Carburising,
- 3) Liquid Carburising.

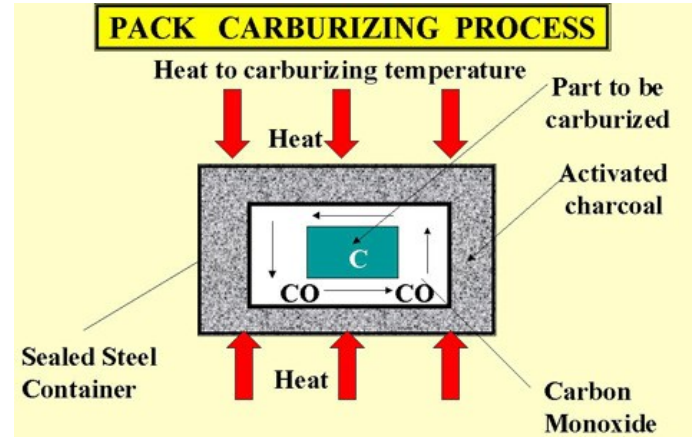

C = Carbon on the surface of the part
 CO = Carbon monoxide gas that is circulated around the part

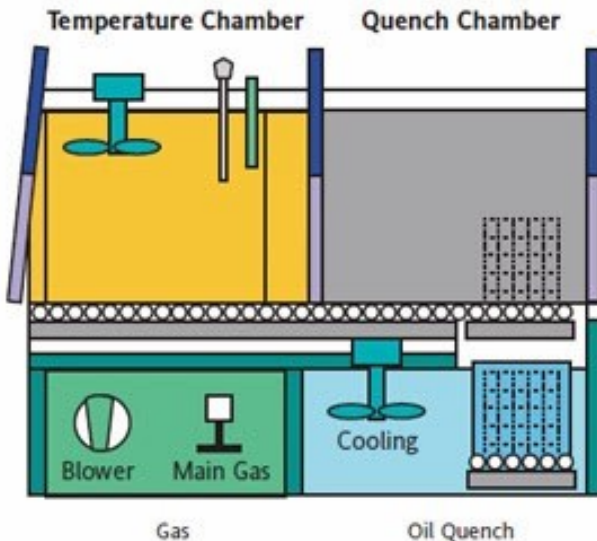

Gas Carburising



Liquid Carburising

Surface Hardening: Nitriding

➤ Nitriding involves diffusion of nitrogen into the product to form nitrides. The resulting nitride case can be harder than the carburized steel. This process is used for alloy steels containing alloying elements (Aluminum, Chromium and Molybdenum) which form stable nitrides.

➤ Nitriding consists of heating a component in a retort to a temperature of about 500 to 600 °C. Through the retort the ammonia gas is allowed to circulate. At this temperature the ammonia dissociates by the following reaction.



➤ The atomic nitrogen diffuses into steel surface, and combines with the alloying elements (Cr, Mo, W, V etc) to form hard nitrides. The depth to which nitrides are formed in the steel depends on the temperature and the time allowed for the reaction. After the nitriding the job is allowed to cool slowly. Since there is no quenching involved, chances of cracking and distortion of the component are less.

Heat Treatment

Surface Hardening: Nitriding

- The depth of nitrided case ranges from 0.2 to 0.4 mm and no machining is done after nitriding.
- Nitriding increase wear and corrosion resistance and fatigue strength of the steel. Since nitriding is done at low temperature, it requires more time than carburising, and also the capital cost if the plant is higher than carburising.

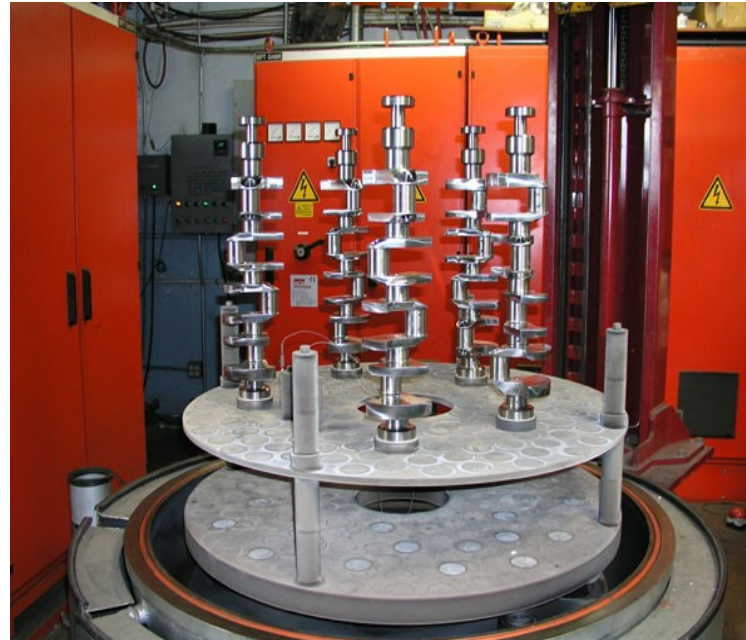
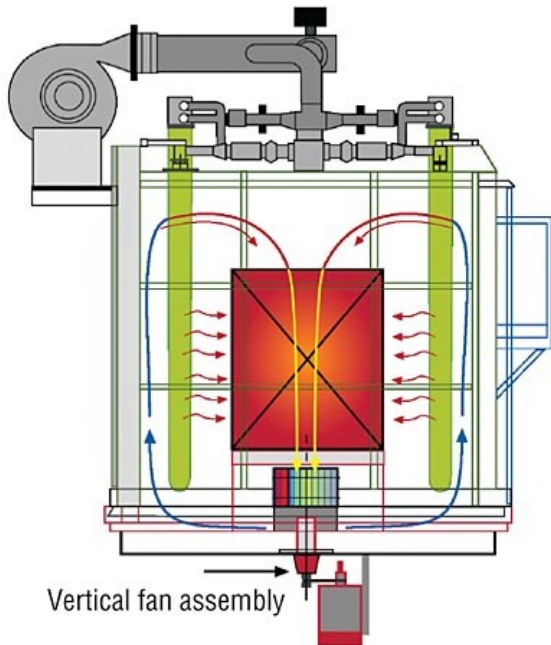

Surface Hardening: Cyaniding

- Similar to carbonitriding, cyaniding also involves the diffusion of carbon and nitrogen into the surface of steel. It is also called liquid carbonitriding. The components are heated to the temperature of about 800 – 900 oC in a molten cyanide bath consisting of sodium cyanide, sodium carbonate and sodium chloride.
- After allowing the components in the bath for about 15 – 20 minutes, they are quenched in oil or water. Cyaniding is normally used for low-carbon steels, and case depths are usually less than 0.25 mm.
- It produces hard and wear resistance surface on the steels. Because of shorter time cycles, the process is widely used for the machine components subjected to moderate wear and service loads.
- The process is particularly suitable for screws, small gears, nuts and bolts.

End of UNIT - 5

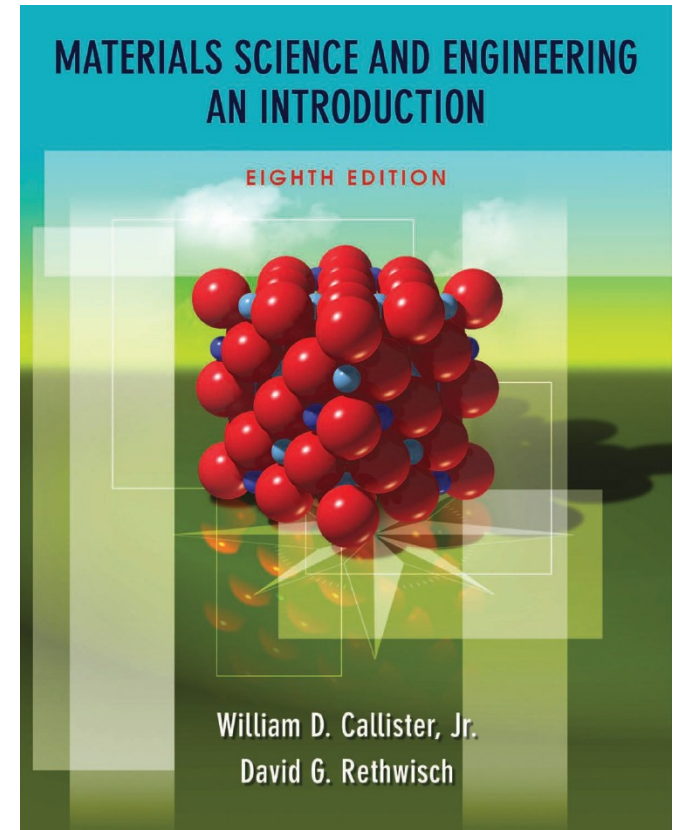

Please read the book.